

LANDRUNNER II • LANDRUNNER II • LAND  
RUNNER II • LANDRUNNER II • LAND  
BLU-JET  
RUNNER II • LANDRUNNER II • LAND  
LANDRUNNER II • LANDRUNNER II • LAND  
RUNNER II • LANDRUNNER II • LANDRUN  
LANDRUNNER II • LANDRUNNER II • LAND  
RUNNER II • LANDRUNNER II • LAND  
RUNNER II • LANDRUNNER II • LAND  
RUNNER II • LANDRUNNER II • LAND

# LANDRUNNER II™

## Fertilizer Injection Applicator

**Field Proven**



R  
L  
R  
L  
R  
L  
R  
L  
R  
L  
R  
L  
R  
L  
R  
L  
R  
L  
R  
L

## Versatile, Tough... Built To Handle Any Terrain

- ▶ 4" X 6" Double Bar Mainframe & Wings
- ▶ 180 Degree Fold Extension Wings On 37' and 41' Applicators
- ▶ Hydraulic Wing Cylinder Rocker Plates
- ▶ Swath Widths From 27.5 to 42.5
- ▶ 38" Toolbar Rank
- ▶ Capable of 12 & 16 Row StripTill Operations
- ▶ 5 Year Frame Warranty



RUNNER II • LANDRUNNER II • LANDRUN  
LANDRUNNER II • LANDRUNNER II • LAND  
RUNNER II • LANDRUNNER II • LANDRUN

# LANDRUNNER II™

## Fertilizer Injection Applicator

Designed and built to rugged **BLU-JET** standards. The **LANDRUNNER II's** heavy 4" x 6" tubular framework with deep penetrating welds at critical points give you the strength to tackle any terrain. Versatile row spacing capabilities meet your needs for pre-plant, side-dress and striptill. Deep toolbar rank provides superior residue flow.

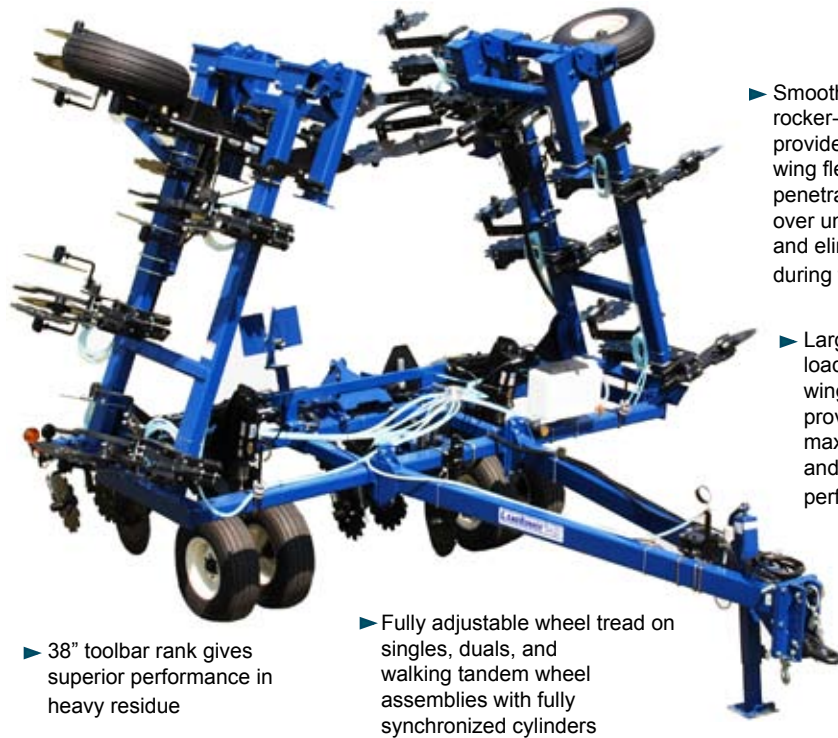

37' 15R30  
180 Degree Fold  
Extension Wing

▶ Smooth-operating rocker-plate design provides excellent wing flex to keep knife penetration uniform over uneven terrain and eliminates wing fall during folding

▶ Large, 1-3/4" load bearing wing hinge pins provide long life, maximum flexibility and superior performance

▶ Wheatland and clevis hitch choices match your needs while keeping the 30,400 lb. safety chain within ASAE standard

▶ Fully adjustable wheel tread on singles, duals, and walking tandem wheel assemblies with fully synchronized cylinders

▶ 38" toolbar rank gives superior performance in heavy residue

### Specifications:

Mainframe.....	Heavy Duty 4" x 6" x 3/8" Mainframe
Tongue.....	6" x 4" Weighted A-Frame Tongue
Models.....	27', 31', 37', 41'
Wheel Lift & Gauge Wheel Lift.....	Single Wheel Lift W/Single Gauge Wheel Dual Wheel Lift W/Hydraulic Single Gauge Wheel Walking Tandem Wheel Lift W/Tandem Gauge Wheel
Wheel Lift Tires & Rims.....	11L-15 12-Ply Single 11L-15 8-Ply Duals and Walkers 11L-15 12 Ply Duals and Walkers
Gauge Wheels Hydraulic Tires & Rims.....	11L-15 8-Ply Single Gauge Wheel Lift 11L-15 8-Ply Duals and Walkers
Gauge Wheels.....	Pin Adjust Manual Gauge Wheels
Gauge Wheel Tires Manual.....	25 x 7.50-15, 4 ply
Wing Flex.....	11 Degrees Down, 16 Degrees Up (Primary Wing)
Transport Width.....	16'-10" (17R30")
Transport Height.....	13'-4"
Row spacings.....	15, 18, 30", or 36"
Coulters.....	Super 1200 Coulters with 20" Fluted Blades
Shanks.....	1" x 2" Flat, 1-1/4" x 2" Edge Bent
Clamps.....	Rigid, Spring Cushion, MaxPac
Optional.....	<b>BLU-JET</b> SealPro II Sealers
Sealer Blades.....	18" Hoe Wheel, 17" x 3/4" x 12" Wave, 17" Notched (Blunt)
Nurse Tank Hitch.....	BLU-JET AutoLok Nurse Tank Hitch
Distribution.....	John Blue Impellicone Manifold Distribution for GDI 200 or 9500 Meter
NH <sub>3</sub> Supply Connection.....	SuperShooter III Assembly (Less meter & Distribution)
Emergency Water Tank/Toolbox.....	Standard
9000 lb./ Parking Jack.....	Standard
Lighting Kit.....	Standard
5-Year Frame Warranty	

**Find Out More...Call the BLU-JET Hotline (800-658-3127) Today**

**Thurston Manufacturing Company • 1708 H Ave • Box 218 • Thurston, Nebraska, 68062-0218**  
**Phone: 402-385-3041 • Fax: 402-385-3043 • E-mail: box218@thurstonmfgco.com**  
[www.thurstonmfgco.com](http://www.thurstonmfgco.com)



## Your Partner for Conservation Farming



**AutoLok nurse tank hitch has the largest hitching envelop in the industry, and it retracts for hitching and pulls out to latch**



**The BLU-JET Bodyguard on the exclusive SuperShooter III helps protect the operator from ammonia spray back during coupling. It features a multi-directional swivel and highly visible operational information**

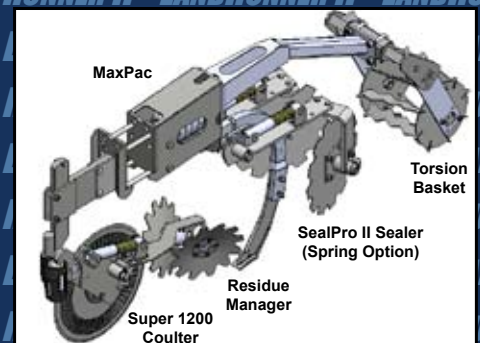

**Mount BLU-JET StripTill Row Units on your LandRunner II for a 12 or 16 row StripTill applicator**

Distributed By: