



# BLU-JET MaxPac AR700

**Field  
Proven**

## **790 lb. Trip Force** **Ten Inches of Trip Height**

The **MaxPac AR700** is Powerfully Effective in difficult and stony soils. Tests have proven the **790 lb. trip force** to be the ideal balance between tripping the spring before shearing a knife bolt at 6+mph. A full

**ten inches of trip height** resets automatically due to the unique leverages built into the mechanism. And best yet, daily service is not required as **greaseless bearing pivot points** provide unmatched durability.

**MaxPac AR700** is fully compatible with BLU-JET StripTill Components including Super 1200 Coulters, Spring Loaded Residue Managers, 1-1/4" x 2" Edge Bent Shanks, SealPro Hillers and Rubber Torsion Mounted Baskets. This combination builds the optimum planting ridge.

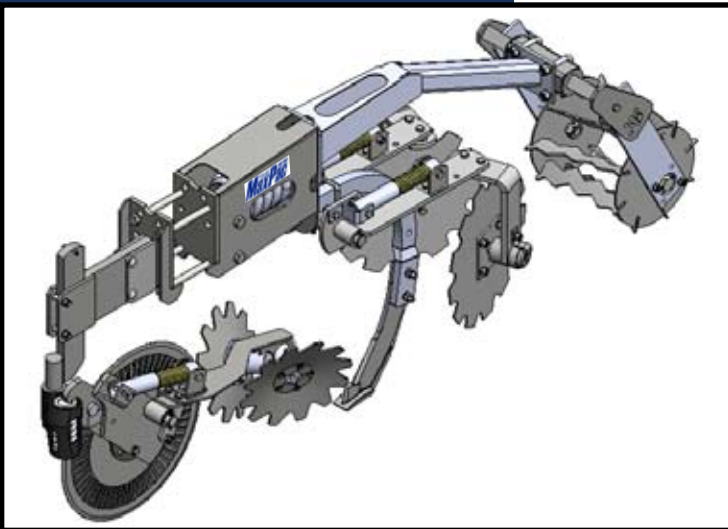



# BLU-JET MaxPac AR700

StripTill or Conventional  
Fertilizer Injection Row Units

“Auto Reset Holding Power to Spare”

Fits Toolbar Sizes:

4 x 4, 4 x 6, 6 x 4, 6 x 6, 7 x 5 and 7 x 7

Modular **BLU-JET** Components Options:

- Super 1200 Coultter
- Residue Manager-Leaf spring/adjustable depth
- SealPro Hillers-Floating, self digging design, 3 blade choices
- Rolling Basket-Rubber torsion tube mounted, QuickAdjust tension, no spring

**Pre-Lubricated Pivot Action**

**....No Greasing Required**

Just what you'd expect from the  
MARKET LEADER  
**BLU-JET**

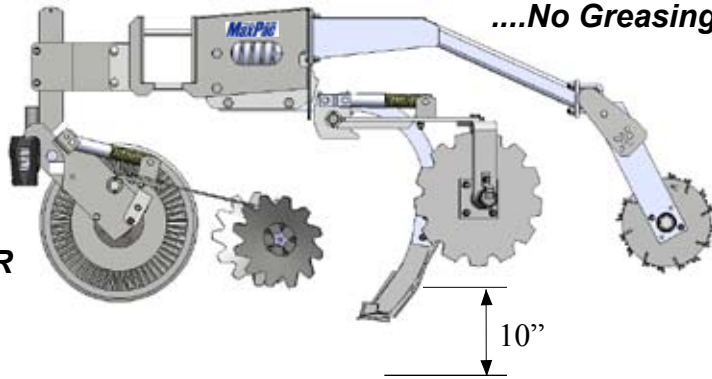

**~2000 lbs. Re-entry Force**

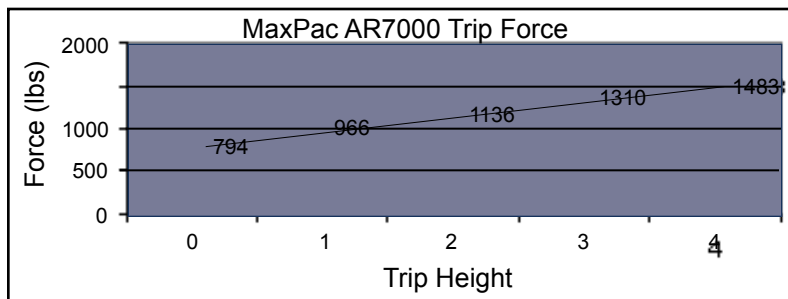

**Find Out More...Call the BLU-JET Hotline  
(800-658-3127) Today**  
Thurston Manufacturing Company • 1708 H Ave • Box 218  
Thurston, Nebraska, 68062-0218  
Phone: 402-385-3041 • Fax: 402-385-3043 •  
E-mail: box218@thurstonmfgco.com • www.thurstonmfgco.com

Design specifications and features as described are subject to change without notice.  
BLU-JET is a registered trademark of Thurston Manufacturing Company, Thurston NE.  
Copyright 2010 Thurston Manufacturing Company Form No.15MaxPac-0610TM

Distributed By: